

## General Description

SkyHigh S34ML16G2 16-Gb NAND is offered in 3.3 V<sub>CC</sub> with x8 I/O interface. This document contains information for the S34ML16G2 device, which is a quad-die stack of four S34ML04G2 die. For detailed specifications, please refer to the discrete die data sheet: S34ML01G2\_04G2.

## Distinctive Characteristics

- Density
  - 16-Gb (4-Gb × 4)
- Architecture (For each 4-Gb device)
  - Input / Output Bus Width: 8-bits
  - Page Size: (2048 + 128) bytes; 128-byte spare area
  - Block Size: 64 Pages or (128k + 8k) bytes
  - Plane Size
    - 2048 Blocks per Plane or (256M + 16M) bytes
  - Device Size
    - 2 Planes per Device or 512 Mbyte
- NAND Flash Interface
  - Open NAND Flash Interface (ONFI) 1.0 compliant
  - Address, Data and Commands multiplexed
- Supply Voltage
  - 3.3 V device: V<sub>cc</sub> = 2.7 V ~ 3.6 V
- Security
  - One Time Programmable (OTP) area
  - Serial number (unique ID)
  - Hardware program/erase disabled during power transition
- Additional Features
  - Supports Multiplane Program and Erase commands
  - Supports Copy Back Program
  - Supports Multiplane Copy Back Program
  - Supports Read Cache
- Electronic Signature
  - Manufacturer ID: 01h
- Operating Temperature
  - Industrial: –40 °C to 85 °C

## Performance

- Page Read / Program
  - Random access: 30 μs (Max)
  - Sequential access: 25 ns (Min)
  - Program time / Multiplane Program time: 300 μs (Typ)
- Block Erase / Multiplane Erase
  - Block Erase time: 3.5 ms (Typ)
- Reliability
  - 100,000 Program / Erase cycles (Typ)  
(with 4-bit ECC per 528 bytes)
  - 10 Year Data retention (Typ)
  - Blocks zero and one are valid and will be valid for at least 1000 program-erase cycles with ECC
- Package Options
  - Lead Free and Low Halogen
  - 48-Pin TSOP 12 × 20 × 1.2 mm
  - 63-Ball BGA 9 × 11 × 1.2 mm

## Contents

<b>General Description</b> .....	1	<b>7. Electrical Characteristics</b> .....	12
<b>Distinctive Characteristics</b> .....	1	7.1 Valid Blocks .....	12
<b>Performance</b> .....	1	7.2 DC Characteristics .....	12
<b>1. Connection Diagram</b> .....	3	7.3 Pin Capacitance .....	12
<b>2. Pin Description</b> .....	4	7.4 Power Consumptions and Pin Capacitance for Allowed Stacking Configurations .....	13
<b>3. Block Diagrams</b> .....	5	<b>8. Physical Interface</b> .....	14
<b>4. Addressing</b> .....	7	8.1 Physical Diagram .....	14
<b>5. Read Status Enhanced</b> .....	7	<b>9. Ordering Information</b> .....	16
<b>6. Read ID</b> .....	8	<b>10. Document History</b> .....	17
6.1 Read Parameter Page .....	9		

# 1. Connection Diagram

Figure 1.1 48-Pin TSOP1 Contact x8 Device (2 CE#, 16 Gb)

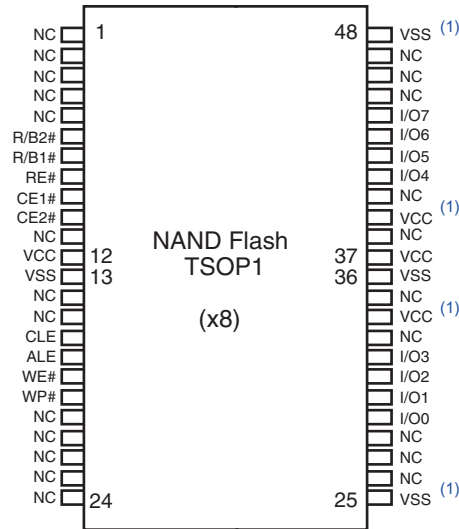

**Note:**

1. These pins should be connected to power supply or ground (as designated) following the ONFI specification, however they might not be bonded internally.

Figure 1.2 63-BGA Contact, x8 Device (Balls Down, Top View)

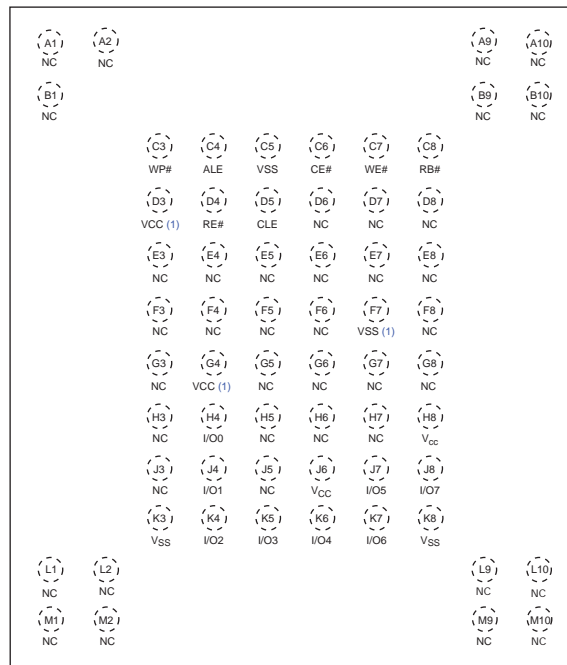

**Note:**

1. These pins should be connected to power supply or ground (as designated) following the ONFI specification, however they might not be bonded internally.

## 2. Pin Description

### Pin Description

Pin Name	Description
I/O0 - I/O7	<b>Inputs/Outputs.</b> The I/O pins are used for command input, address input, data input, and data output. The I/O pins float to High-Z when the device is deselected or the outputs are disabled.
CLE	<b>Command Latch Enable.</b> This input activates the latching of the I/O inputs inside the Command Register on the rising edge of Write Enable (WE#).
ALE	<b>Address Latch Enable.</b> This input activates the latching of the I/O inputs inside the Address Register on the rising edge of Write Enable (WE#).
CE#	<b>Chip Enable.</b> This input controls the selection of the device. When the device is not busy CE# low selects the memory.
WE#	<b>Write Enable.</b> This input latches Command, Address and Data. The I/O inputs are latched on the rising edge of WE#.
RE#	<b>Read Enable.</b> The RE# input is the serial data-out control, and when active drives the data onto the I/O bus. Data is valid $t_{REA}$ after the falling edge of RE# which also increments the internal column address counter by one.
WP#	<b>Write Protect.</b> The WP# pin, when low, provides hardware protection against undesired data modification (program / erase).
R/B#	<b>Ready Busy.</b> The Ready/Busy output is an Open Drain pin that signals the state of the memory.
VCC	<b>Supply Voltage.</b> The $V_{CC}$ supplies the power for all the operations (Read, Program, Erase). An internal lock circuit prevents the insertion of Commands when $V_{CC}$ is less than $V_{LKO}$ .
VSS	<b>Ground.</b>
NC	<b>Not Connected.</b>

**Notes:**

1. A 0.1  $\mu$ F capacitor should be connected between the  $V_{CC}$  Supply Voltage pin and the  $V_{SS}$  Ground pin to decouple the current surges from the power supply. The PCB track widths must be sufficient to carry the currents required during program and erase operations.
2. An internal voltage detector disables all functions whenever  $V_{CC}$  is below 1.8V to protect the device from any involuntary program/erase during power transitions.

### 3. Block Diagrams

Figure 3.1 Functional Block Diagram — 16 Gb

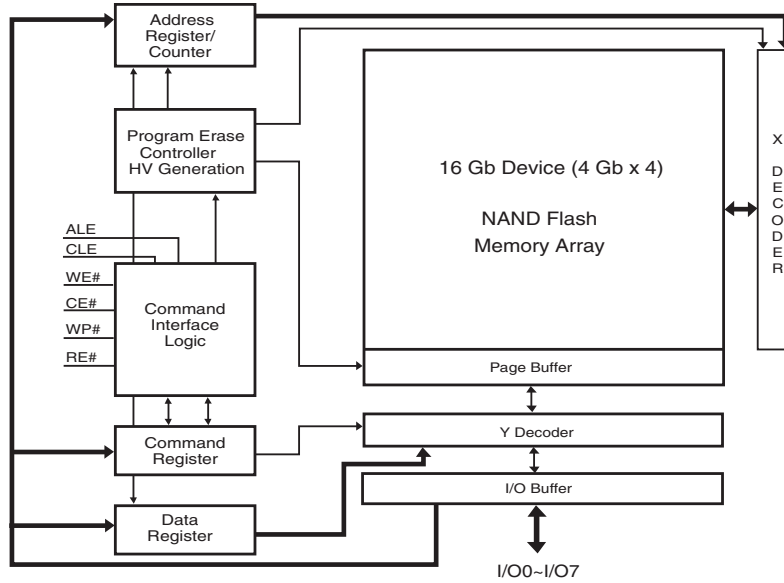

Figure 3.2 Block Diagram — 16 Gb (4 Gb x 4) 48-Pin TSOP with 2 CE# (Two Chip Enable Signals)

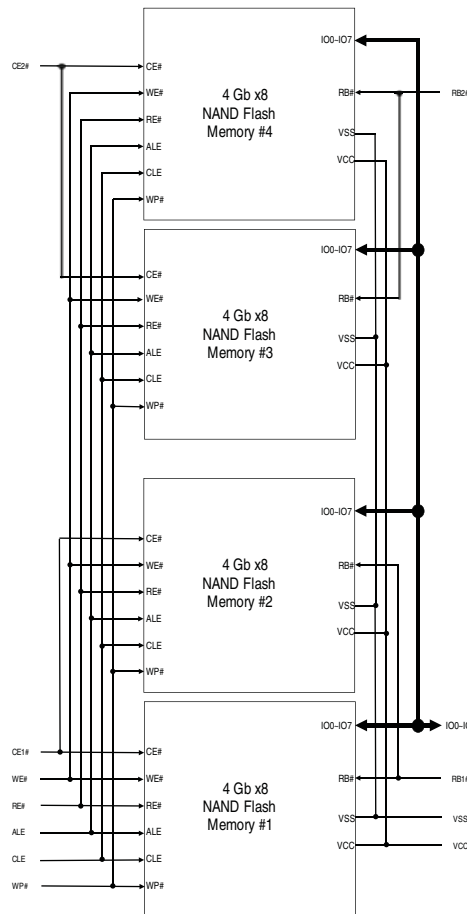
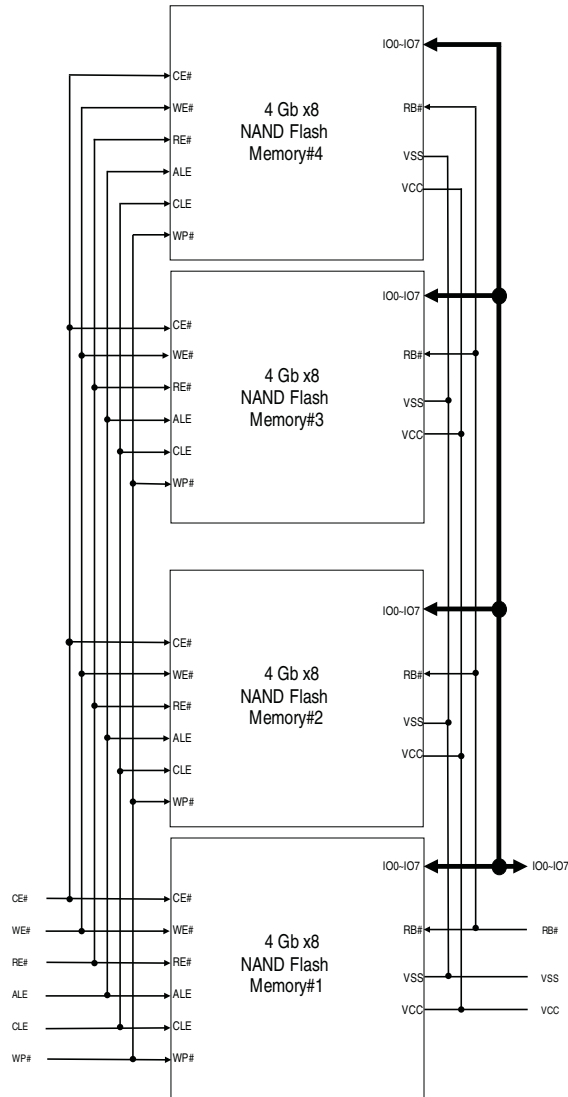

Figure 3.3 Block Diagram — 16 Gb (4 Gb x 4) 63-Ball BGA with 1 CE# (One Chip Enable Signal)



## 4. Addressing

### Address Cycle Map

Bus Cycle	I/O0	I/O1	I/O2	I/O3	I/O4	I/O5	I/O6	I/O7
1st / Col. Add. 1	A0 (CA0)	A1 (CA1)	A2 (CA2)	A3 (CA3)	A4 (CA4)	A5 (CA5)	A6 (CA6)	A7 (CA7)
2nd / Col. Add. 2	A8 (CA8)	A9 (CA9)	A10 (CA10)	A11 (CA11)	Low	Low	Low	Low
3rd / Row Add. 1	A12 (PA0)	A13 (PA1)	A14 (PA2)	A15 (PA3)	A16 (PA4)	A17 (PA5)	A18 (PLA0)	A19 (BA0)
4th / Row Add. 2	A20 (BA1)	A21 (BA2)	A22 (BA3)	A23 (BA4)	A24 (BA5)	A25 (BA6)	A26 (BA7)	A27 (BA8)
5th / Row Add. 3(6)	A28 (BA9)	A29 (BA10)	A30 (BA11)	A31 (BA12)	Low	Low	Low	Low

#### Notes:

1. CAx = Column Address bit.
2. PAx = Page Address bit.
3. PLA0 = Plane Address bit zero.
4. BAx = Block Address bit.
5. Block address concatenated with page address and plane address = actual page address, also known as the row address.
6. A31 for 16 Gb (4 Gb x 4 - QDP)

For the address bits, the following rules apply:

- A0 - A11: column address in the page
- A12 - A17: page address in the block
- A18: plane address (for multiplane operations) / block address (for normal operations)
- A19 - A31: block address

## 5. Read Status Enhanced

Read Status Enhanced is used to retrieve the status value for a previous operation in the following cases:

- In the case of concurrent operations on a multi-die stack.

When four dies are stacked to form a quad-die package (QDP), it is possible to run one operation on the first die, then activate a different operation on the second die, for example: Erase while Read, Read while Program, etc.

- In the case of multiplane operations in the same die.

## 6. Read ID

The device contains a product identification mode, initiated by writing 90h to the command register, followed by an address input of 00h.

**Note:** If you want to execute Read Status command (0x70) after Read ID sequence, you should input dummy command (0x00) before Read Status command (0x70).

For the S34ML16G2 device, five read cycles sequentially output the manufacturer code (01h), and the device code and 3rd, 4th, and 5th cycle ID, respectively. The command register remains in Read ID mode until further commands are issued to it.

### Read ID for Supported Configurations

Density	Org	V <sub>CC</sub>	1st	2nd	3rd	4th	5th
4 Gb	x8	3.3V	01h	DCh	90h	95h	56h
16 Gb (4 Gb x 4 – QDP with one CE#)	x8	3.3V	01h	D5h	D2h	95h	5Eh
16 Gb (4 Gb x 4 – QDP with two CE#)	x8	3.3V	01h	D3h	D1h	95h	5Ah

**Figure 6.1** Read ID Operation Timing

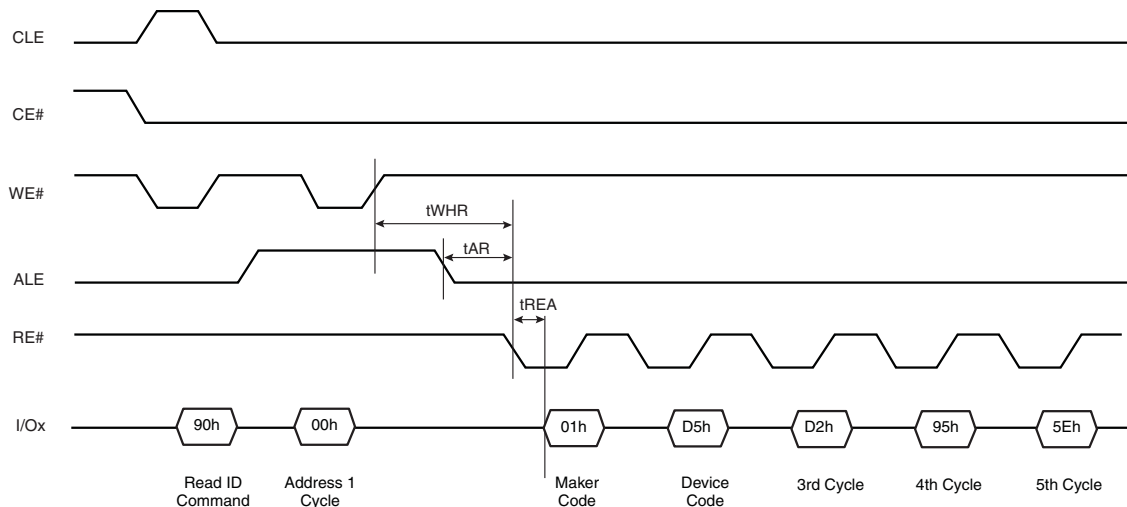



**5<sup>th</sup> ID Data**
**Read ID Byte 5 Description**

	Description	I/O7	I/O6 I/O5 I/O4	I/O3 I/O2	I/O1 I/O0
ECC Level	1 bit / 512 bytes				0 0
	2 bit / 512 bytes				0 1
	4 bit / 512 bytes				1 0
	8 bit / 512 bytes				1 1
Plane Number	1			0 0	
	2			0 1	
	4			1 0	
	8			1 1	
Plane Size (without spare area)	64 Mb		0 0 0		
	128 Mb		0 0 1		
	256 Mb		0 1 0		
	512 Mb		0 1 1		
	1 Gb		1 0 0		
	2 Gb		1 0 1		
	4 Gb		1 1 0		
Reserved		0			

**6.1 Read Parameter Page**

The device supports the ONFI Read Parameter Page operation, initiated by writing ECh to the command register, followed by an address input of 00h. The command register remains in Parameter Page mode until further commands are issued to it. [Table](#) explains the parameter fields.

**Note:** For 32nm SkyHigh NAND, for a particular condition, the Read Parameter Page command does not give the correct values. To overcome this issue, the host must issue a Reset command before the Read Parameter Page command. Issuance of Reset before the Read Parameter Page command will provide the correct values and will not output 00h values.

**Parameter Page Description**

Byte	O/M	Description	Values
<b>Revision Information and Features Block</b>			
0-3	M	Parameter page signature Byte 0: 4Fh, "O" Byte 1: 4Eh, "N" Byte 2: 46h, "F" Byte 3: 49h, "I"	4Fh, 4Eh, 46h, 49h
4-5	M	Revision number 2-15 Reserved (0) 1 1 = supports ONFI version 1.0 0 Reserved (0)	02h, 00h
6-7	M	Features supported 5-15 Reserved (0) 4 1 = supports odd to even page Copyback 3 1 = supports interleaved operations 2 1 = supports non-sequential page programming 1 1 = supports multiple LUN operations 0 1 = supports 16-bit data bus width	1Eh, 00h
8-9	M	Optional commands supported 6-15 Reserved (0) 5 1 = supports Read Unique ID 4 1 = supports Copyback 3 1 = supports Read Status Enhanced 2 1 = supports Get Features and Set Features 1 1 = supports Read Cache commands 0 1 = supports Page Cache Program command	3Bh, 00h

**Parameter Page Description (Continued)**

Byte	O/M	Description	Values
10-31		Reserved (0)	00h
<b>Manufacturer Information Block</b>			
32-43	M	Device manufacturer (12 ASCII characters)	53h, 50h, 41h, 4Eh, 53h, 49h, 4Fh, 4Eh, 20h, 20h, 20h, 20h
44-63	M	Device model (20 ASCII characters)	53h, 33h, 34h, 4Dh, 4Ch, 31h, 36h, 47h, 32h, 20h, 20h, 20h, 20h, 20h, 20h, 20h, 20h, 20h, 20h, 20h
64	M	JEDEC manufacturer ID	01h
65-66	O	Date code	00h
67-79		Reserved (0)	00h
<b>Memory Organization Block</b>			
80-83	M	Number of data bytes per page	00h, 08h, 00h, 00h
84-85	M	Number of spare bytes per page	80h, 00h
86-89	M	Number of data bytes per partial page	00h, 00h, 00h, 00h
90-91	M	Number of spare bytes per partial page	00h, 00h
92-95	M	Number of pages per block	40h, 00h, 00h, 00h
96-99	M	Number of blocks per logical unit (LUN)	00h, 40h, 00h, 00h (1 CE#) 00h, 20h, 00h, 00h (2 CE#)
100	M	Number of logical units (LUNs)	01h (1 CE#) 02h (2 CE#)
101	M	Number of address cycles 4-7 Column address cycles 0-3 Row address cycles	23h
102	M	Number of bits per cell	01h
103-104	M	Bad blocks maximum per LUN	47h, 01h (1 CE#) A3h, 00h (2 CE#)
105-106	M	Block endurance	01h, 05h
107	M	Guaranteed valid blocks at beginning of target	01h
108-109	M	Block endurance for guaranteed valid blocks	01h, 03h
110	M	Number of programs per page	04h
111	M	Partial programming attributes 5-7 Reserved 4 1 = partial page layout is partial page data followed by partial page spare 1-3 Reserved 0 1 = partial page programming has constraints	00h
112	M	Number of bits ECC correctability	04h
113	M	Number of interleaved address bits 4-7 Reserved (0) 0-3 Number of interleaved address bits	01h
114	O	Interleaved operation attributes 4-7 Reserved (0) 3 Address restrictions for program cache 2 1 = program cache supported 1 1 = no block address restrictions 0 Overlapped / concurrent interleaving support	04h
115-127		Reserved (0)	00h
<b>Electrical Parameters Block</b>			
128	M	I/O pin capacitance	0Ah

**Parameter Page Description (Continued)**

Byte	O/M	Description	Values
129-130	M	Timing mode support 6-15 Reserved (0) 5 1 = supports timing mode 5 4 1 = supports timing mode 4 3 1 = supports timing mode 3 2 1 = supports timing mode 2 1 1 = supports timing mode 1 0 1 = supports timing mode 0, shall be 1	1Fh, 00h
131-132	O	Program cache timing mode support 6-15 Reserved (0) 5 1 = supports timing mode 5 4 1 = supports timing mode 4 3 1 = supports timing mode 3 2 1 = supports timing mode 2 1 1 = supports timing mode 1 0 1 = supports timing mode 0	1Fh, 00h
133-134	M	t <sub>PROG</sub> Maximum page program time (μs)	BCh, 02h
135-136	M	t <sub>BERS</sub> Maximum block erase time (μs)	10h, 27h
137-138	M	t <sub>R</sub> Maximum page read time (μs)	1Eh, 00h
139-140	M	t <sub>CCS</sub> Minimum Change Column setup time (ns)	C8h, 00h
141-163		Reserved (0)	00h
<b>Vendor Block</b>			
164-165	M	Vendor specific Revision number	00h
166-253		Vendor specific	00h
254-255	M	Integrity CRC	6Fh, D9h (1CE#) 15h, 32h (2CE#)
<b>Redundant Parameter Pages</b>			
256-511	M	Value of bytes 0-255	Repeat Value of bytes 0-255
512-767	M	Value of bytes 0-255	Repeat Value of bytes 0-255
768+	O	Additional redundant parameter pages	FFh

**Note:**

1. "O" Stands for Optional, "M" for Mandatory.

## 7. Electrical Characteristics

### 7.1 Valid Blocks

#### Valid Blocks

Device	Symbol	Min	Typ	Max	Unit
S34ML04G2	N <sub>VB</sub>	4016	—	4096	Blocks
S34ML16G2 (1 CE)	N <sub>VB</sub>	16057	—	16384	Blocks
S34ML16G2 (2 CE)	N <sub>VB</sub>	16058	—	16384	Blocks

### 7.2 Recommended Operating Conditions

#### Recommended Operating Conditions

Parameter	Symbol	Min	Typ	Max	Units
V <sub>CC</sub> Supply Voltage	V <sub>CC</sub>	2.7	3.3	3.6	V
Ground Supply Voltage	V <sub>SS</sub>	0	0	0	V

### 7.3 DC Characteristics

DC Characteristics and Operating Conditions (Values listed are for each 4 Gb NAND, 16 Gb (4 Gb x 4) will differ accordingly)

Parameter	Symbol	Test Conditions	Min	Typ	Max	Units
Power On Current	I <sub>CC0</sub>	FFh command input after power on	—	—	50 per device	mA
Operating Current	Sequential Read	t <sub>RC</sub> = t <sub>RC</sub> (min) CE# = V <sub>IL</sub> , I <sub>out</sub> = 0 mA	—	15	30	mA
	Program	Normal	—	15	30	mA
		Cache	—	—	15	30
Erase	I <sub>CC3</sub>	—	—	15	30	mA
Standby Current, (TTL)	I <sub>CC4</sub>	CE# = V <sub>IH</sub> , WP# = 0V/V <sub>CC</sub>	—	—	1	mA
Standby Current, (CMOS)	I <sub>CC5</sub>	CE# = V <sub>CC</sub> -0.2, WP# = 0/V <sub>CC</sub>	—	10	50	μA
Input Leakage Current	I <sub>LI</sub>	V <sub>IN</sub> = 0 to V <sub>CC</sub> (max)	—	—	±10	μA
Output Leakage Current	I <sub>LO</sub>	V <sub>OUT</sub> = 0 to V <sub>CC</sub> (max)	—	—	±10	μA
Input High Voltage	V <sub>IH</sub>	—	V <sub>CC</sub> x 0.8	—	V <sub>CC</sub> + 0.3	V
Input Low Voltage	V <sub>IL</sub>	—	-0.3	—	V <sub>CC</sub> x 0.2	V
Output High Voltage	V <sub>OH</sub>	I <sub>OH</sub> = -400 μA	2.4	—	—	V
Output Low Voltage	V <sub>OL</sub>	I <sub>OL</sub> = 2.1 mA	—	—	0.4	V
Output Low Current (R/B#)	I <sub>OL(R/B#)</sub>	V <sub>OL</sub> = 0.4V	8	10	—	mA
Erase and Program Lockout Voltage	V <sub>LKO</sub>	—	—	1.8	—	V

#### Notes:

1. All V<sub>CC</sub> pins, and V<sub>SS</sub> pins respectively, are shorted together.
2. Values listed in this table refer to the complete voltage range for V<sub>CC</sub> and to a single device in case of device stacking.
3. All current measurements are performed with a 0.1 μF capacitor connected between the V<sub>CC</sub> Supply Voltage pin and the V<sub>SS</sub> Ground pin.
4. Standby current measurement can be performed after the device has completed the initialization process at power up.

## 7.4 Pin Capacitance

Pin Capacitance (TA = 25°C, f = 1.0 MHz)

Parameter	Symbol	Test Condition	Min	Max	Unit
Input	C <sub>IN</sub>	V <sub>IN</sub> = 0V	—	10	pF
Input / Output	C <sub>IO</sub>	V <sub>IL</sub> = 0V	—	10	pF

**Note:**

1. For the stacked devices version the Input is 10 pF x [number of stacked chips] and the Input/Output is 10 pF x [number of stacked chips].

## 7.5 Power Consumptions and Pin Capacitance for Allowed Stacking Configurations

When multiple dies are stacked in the same package, the power consumption of the stack will increase according to the number of chips. As an example, the standby current is the sum of the standby currents of all the chips, while the active power consumption depends on the number of chips concurrently executing different operations.

When multiple dies are stacked in the same package the pin/ball capacitance for the single input and the single input/output of the combo package must be calculated based on the number of chips sharing that input or that pin/ball.

## 8. Physical Interface

### 8.1 Physical Diagram

#### 8.1.1 48-Pin Thin Small Outline Package (TSOP1)

Figure 8.1 TS2 48 — 48-lead Plastic Thin Small Outline, 12 x 20 mm, Package Outline

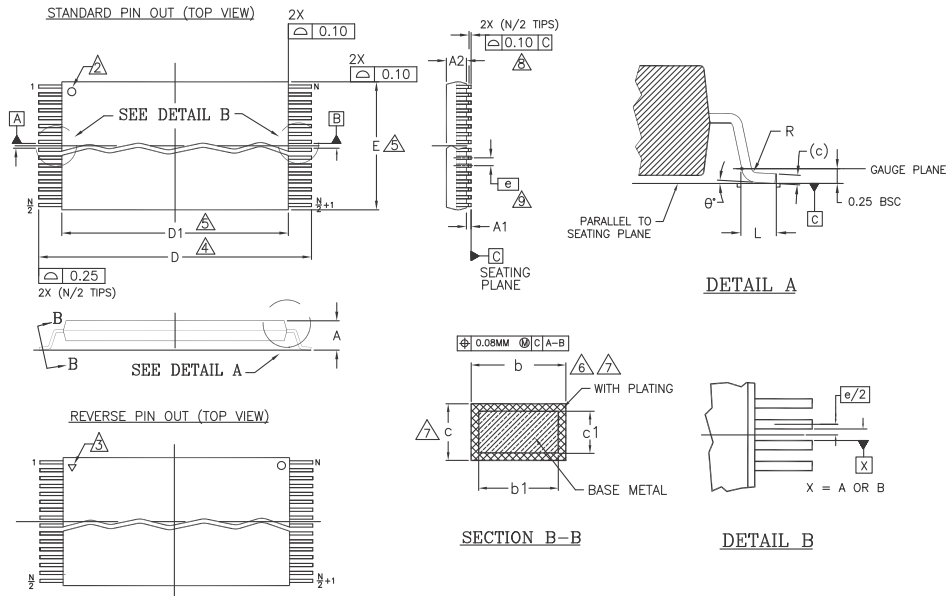

PACKAGE	TS4 48		
JEDEC	MO-142 (D) DD		
SYMBOL	MIN	NOM	MAX
A	---	---	1.20
A1	0.05	---	0.15
A2	0.95	1.00	1.05
b1	0.17	0.20	0.23
b	0.17	0.22	0.27
c1	0.10	---	0.16
c	0.10	---	0.21
D	19.80	20.00	20.20
D1	18.30	18.40	18.50
E	11.90	12.00	12.10
e	0.50 BASIC		
L	0.50	0.60	0.70
Ø	0"	---	8
R	0.08	---	0.20
N	48		

NOTES:

1. DIMENSIONS ARE IN MILLIMETERS (mm). (DIMENSIONING AND TOLERANCING CONFORM TO ANSI Y14.5M-1994).
2. PIN 1 IDENTIFIER FOR STANDARD PIN OUT (DIE UP).
3. PIN 1 IDENTIFIER FOR REVERSE PIN OUT (DIE DOWN); INK OR LASER MARK.
4. TO BE DETERMINED AT THE SEATING PLANE [C-C]. THE SEATING PLANE IS DEFINED AS THE PLANE OF CONTACT THAT IS MADE WHEN THE PACKAGE LEADS ARE ALLOWED TO REST FREELY ON A FLAT HORIZONTAL SURFACE.
5. DIMENSIONS D1 AND E DO NOT INCLUDE MOLD PROTRUSION. ALLOWABLE MOLD PROTRUSION ON E IS 0.15mm PER SIDE AND ON D1 IS 0.25mm PER SIDE.
6. DIMENSION b DOES NOT INCLUDE DAMBAR PROTRUSION. ALLOWABLE DAMBAR PROTRUSION SHALL BE 0.08mm TOTAL IN EXCESS OF b DIMENSION AT MAX. MATERIAL CONDITION. DAMBAR CANNOT BE LOCATED ON LOWER RADIUS OR THE FOOT. MINIMUM SPACE BETWEEN PROTRUSION AND AN ADJACENT LEAD TO BE 0.07mm.
7. THESE DIMENSIONS APPLY TO THE FLAT SECTION OF THE LEAD BETWEEN 0.10mm AND 0.25mm FROM THE LEAD TIP.
8. LEAD COPLANARITY SHALL BE WITHIN 0.10mm AS MEASURED FROM THE SEATING PLANE.
9. DIMENSION "e" IS MEASURED AT THE CENTERLINE OF THE LEADS.

gs5039-ts4 048-09.05.14

### 8.1.2 63-Ball BGA Package

Figure 8.2 63-Ball BGA 9 x 11 x 1.2 mm

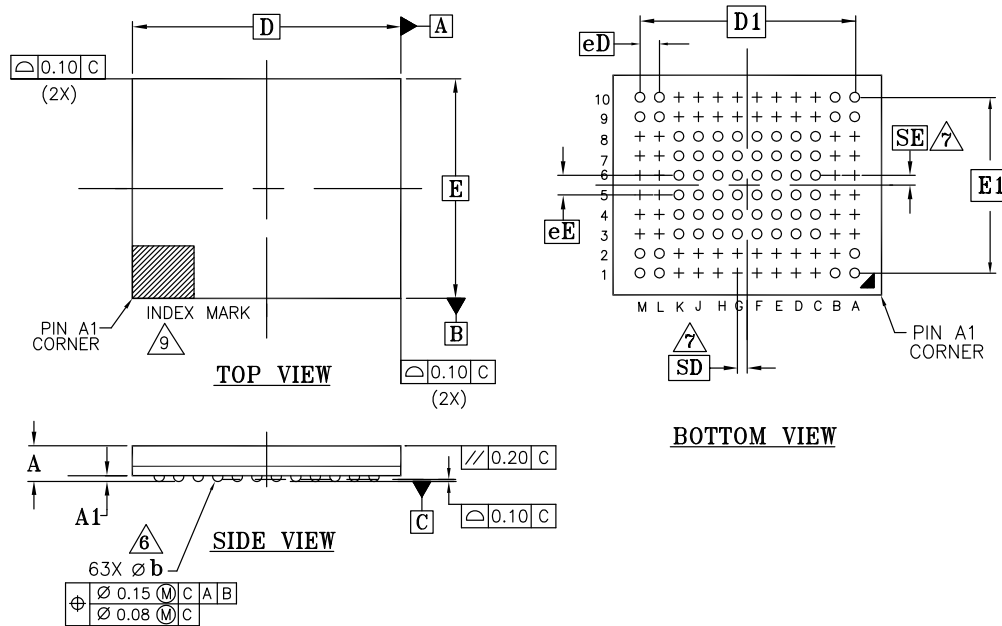

PACKAGE	TNA 063			NOTE
JEDEC	MO-207(N)			
D X E	11.00mm X 9.00mm PACKAGE			
SYMBOL	MIN.	NOM.	MAX.	
A	---	---	1.20	PROFILE
A1	0.25	---	---	BALL HEIGHT
D	11.00 BSC			BODY SIZE
E	9.00 BSC			BODY SIZE
D1	8.80 BSC			MATRIX FOOTPRINT
E1	7.20 BSC			MATRIX FOOTPRINT
MD	12			MATRIX SIZE D DIRECTION
ME	10			MATRIX SIZE E DIRECTION
n	63			BALL COUNT
$\phi b$	0.40	0.45	0.50	BALL DIAMETER
eE	0.80 BSC			BALL PITCH
eD	0.80 BSC			BALL PITCH
SD	0.40 BSC			SOLDER BALL PLACEMENT
SE	0.40 BSC			SOLDER BALL PLACEMENT
	A3-A8,B2-B8,C1,C2,C9,C10,D1,D2,D9,D10,E1,E2,E9,E10,F1,F2,F9,F10,G1,G2,G9,G10,H1,H2,H9,H10,J1,J2,J9,J10,K1,K2,K9,K10,L3-L8,M3-M8			DEPOPULATED SOLDER BALLS

NOTES:

- DIMENSIONING AND TOLERANCING METHODS PER ASME Y14.5M-1994.
- ALL DIMENSIONS ARE IN MILLIMETERS.
- BALL POSITION DESIGNATION PER JEP 95, SECTION 3, SPP-020.
- [e] REPRESENTS THE SOLDER BALL GRID PITCH.
- SYMBOL "MD" IS THE BALL MATRIX SIZE IN THE "D" DIRECTION. SYMBOL "ME" IS THE BALL MATRIX SIZE IN THE "E" DIRECTION. n IS THE NUMBER OF POPULATED SOLDER BALL POSITIONS FOR MATRIX SIZE MD X ME.
  - 6. DIMENSION "b" IS MEASURED AT THE MAXIMUM BALL DIAMETER IN A PLANE PARALLEL TO DATUM C.
  - 7. "SD" AND "SE" ARE MEASURED WITH RESPECT TO DATUMS A AND B AND DEFINE THE POSITION OF THE CENTER SOLDER BALL IN THE OUTER ROW. WHEN THERE IS AN ODD NUMBER OF SOLDER BALLS IN THE OUTER ROW "SD" OR "SE" = 0. WHEN THERE IS AN EVEN NUMBER OF SOLDER BALLS IN THE OUTER ROW "SD" = eD/2 AND "SE" = eE/2.
- "+" INDICATES THE THEORETICAL CENTER OF DEPOPULATED BALLS.
- A1 CORNER TO BE IDENTIFIED BY CHAMFER, LASER OR INK MARK, METALLIZED MARK INDENTATION OR OTHER MEANS.

gs5038-tna063-09.05.14

## 9. Ordering Information

The ordering part number is formed by a valid combination of the following:

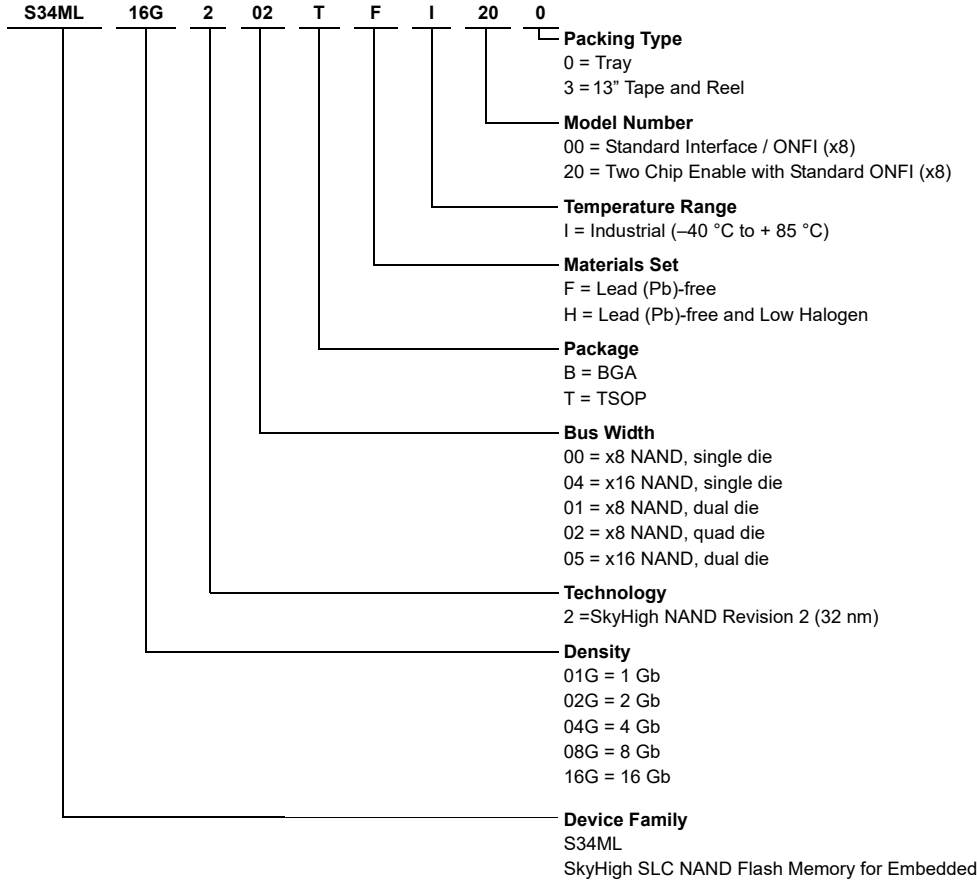

### Valid Combinations

Valid Combinations list configurations planned to be supported in volume for this device. Contact your local sales office to confirm availability of specific valid combinations and to check on newly released combinations.

Valid Combinations								
Device Family	Density	Technology	Bus Width	Package Type	Temperature Range	Additional Ordering Options	Packing Type	Package Description
S34ML	16G	2	02	TF/BH	I	TF - 20 BH - 00	0, 3	BGA TSOP



## 10. Document History

Document Title: S34ML16G2, 16-Gbit, 4-Bit ECC, x8 I/O, 3 V <sub>CC</sub> NAND Flash for Embedded				
Document Number: 001-98528				
Rev.	ECN No.	Orig. of Change	Submission Date	Description of Change
**	–	–	10/28/2014	Initial release (Spansion Publication Number: S34ML16G2)
*A	–	–	06/10/2015	Performance: Corrected Package Options for 63-Ball BGA to 9 x 11 x 1.2 mm Connection Diagram: 63-BGA Contact, x8 Device (Balls Down, Top View) figure: added Note Physical Interface: 63-Ball BGA Package: corrected figure title to '63-Ball BGA 9 x 11 x 1.2 mm'
			08/19/2015	Read ID: Read ID for Supported Configurations table: added 16 Gb (4 Gb x 4 – QDP with two CE#) Electrical Characteristics: Valid Blocks table: added S34ML16G2 (2 CE)
*B	4965191	XILA	10/15/2015	Updated to Cypress template.
*C	5016364	XILA	11/20/2015	Updated to new template.
*D	5160512	XILA	04/25/2016	Updated <a href="#">Read ID</a> : Updated <a href="#">Read Parameter Page</a> : Updated description. Updated <a href="#">Electrical Characteristics</a> : Added <a href="#">Recommended Operating Conditions</a> . Updated <a href="#">DC Characteristics</a> : Replaced "VCC supply Voltage (erase and program lockout)" with "Erase and Program Lockout voltage" in "Parameter" column corresponding to V <sub>LKO</sub> . Updated to new template.
*E	5727817	HARA	05/05/2017	Updated logo and copyright.
*F	6379791	MNAD	11/09/2018	Updated to new template. Completing Sunset Review.
*G		MNAD	05/09/2019	Updated to SkyHigh format